

Torque Sensor

Mini-Smart Torque Sensor

Type 4502A...

Type 4502A... torque sensors operate on the strain gage principle and supply an analog output signal of 0 ... ± 5 VDC which is contactless transferred. Available also with integrated rotational angle-/speed measurement.

- Smart (integral measuring electronics)
- Highly fail safe due to active torque output (± 5 VDC), electrically isolated from supply and measuring signal
- Non-contact signal transfer
- Unipolar supply
- Highly responsive to dynamic peaks
- Maintenance-free
- Standardized mechanical connections:
 - 1/4" hex socket DIN3126
 - Square socket (size depending on measuring range)
 - Cylindrical shaft ends
- Extremely compact
- Suitable for pulse tool operation
- Conforming to CE
- Optional rotational angle measurement

Description

The Mini-Smart torque sensor uses strain gage technology. The torque signal is transmitted from the rotating shaft via frequency modulation and is processed as an analog signal.

The rotational angle signal with two tracks of each 360 pulses per revolution and track is available as TTL-signal. An external electrical calibration input is standard.

Application

The Mini-Smart torque sensor with rotating measuring shaft is suitable both for dynamical detection of starting torque and breakway torque for bolting and assembly techniques and for quality assurance in production and laboratory.

Due to its standardized connections the device can be quickly adapted to air, electronic and pulse tools.



Version Q/QA



Version H/HA



Version R/RA

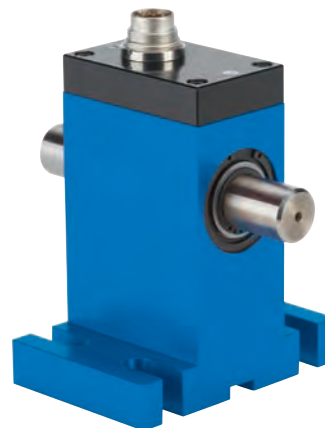

Version RAU

Technical Data

Mechanical Basic Data

Measuring range (nominal torque)	lbf-ft	0.37 ... 737.6
Overload capacity		
Service torque		1.5 x rated torque
Limiting torque		1.5 x rated torque
Rotational angle/- speed measur.	pulses/	2x360,
(Version QA, HA, RA, RAU)	revolut.	90° displaced, TTL
Nominal speed		
≤13.3 lbf-ft	rpm	12,000
14.8 ... 118 lbf-ft	rpm	9,000
184.4 ... 737.6 lbf-ft	rpm	7,000
Version QA, HA, RA, RAU	rpm	7,000
(rotational angle measurement)		
Housing material		Anodized aluminum
Protection class		IP40

General Electrical Specifications

Accuracy class		0.2
Linearity error		
including hysteresis	% FSO	<±0.2
Output signal (rated value)	VDC	±0 ... 5
Temp. influence on the zero point	% FSO/°F	<±0.008
Temp. influence on the nominal value	% FSO/°F	<±0.008
Control signal	%	100 ±0.2
100 % control input	VDC	"ON" >3 (max. 30) "OFF" <1.5
Operating temperature range	°F	50 ... 140
(Rated temperature range)		
Service temperature range	°F	32 ... 158
Storage temperature range	°F	-13 ... 176
Electrical connection		12 pin built-in connector
Supply voltage	VDC	11 ... 26
Power consumption	W	<1

Dimensions

Torque sensor with standard square socket connection

Version Q

- With rotating shaft
- Drive - square socket
- Output - square drive
- Pulse-tool suited, oilproof design (optional)



Table Version Q

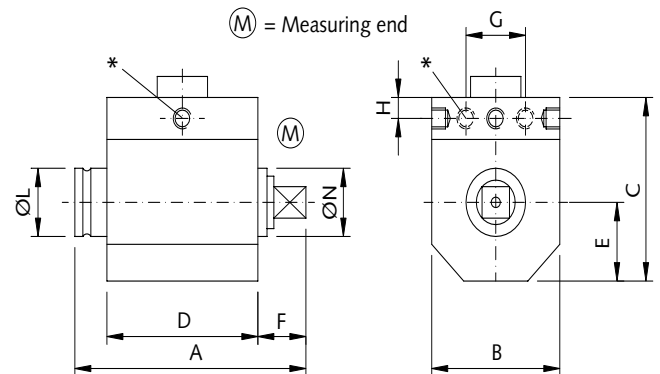

Threads for mounting: M4, 6 mm (0.24 in.) depth

Type	Measuring range lbf-ft	Square size	A	B	C	D	E	F	G	H	I	øL	øN	Axial force lbf max.	Radial force lbf max.
4502A12Q	8.9	1/4"	3.0	1.1	2.0	2.3	0.55	0.33	0.32	0.20	0.43	0.51	0.39	33.7	6.7
4502A18Q	13.3	1/4"	3.0	1.1	2.0	2.3	0.55	0.33	0.32	0.20	0.43	0.51	0.39	33.7	6.7
4502A50Q	36.9	3/8"	2.9	1.5	2.3	1.7	0.75	0.71	*	0.24	0.87	0.99	0.75	112.4	13.5
4502A63Q	46.5	3/8"	2.9	1.5	2.3	1.7	0.75	0.71	*	0.24	0.87	0.99	0.75	112.4	13.5
4502A100Q	73.8	1/2"	3.1	1.5	2.3	1.7	0.75	0.89	*	0.24	0.87	0.99	0.75	157.4	22.5
4502A150Q	110.6	1/2"	3.1	1.5	2.3	1.7	0.75	0.89	*	0.24	0.87	0.99	0.75	224.8	22.5
4502A160Q	118.0	1/2"	3.1	1.5	2.3	1.7	0.75	0.89	*	0.24	0.87	0.99	0.75	224.8	22.5
4502A250Q	184.4	3/4"	3.8	2.3	3.0	2.0	1.1	1.2	*	0.20	0.99	1.6	1.2	449.6	33.7
4502A300Q	221.3	3/4"	3.8	2.3	3.0	2.0	1.1	1.2	*	0.20	0.99	1.6	1.2	449.6	33.7
4502A500Q	368.8	3/4"	3.8	2.3	3.0	2.0	1.1	1.2	*	0.20	0.99	1.6	1.2	449.6	33.7
4502A1KQ	737.6	1"	4.4	2.9	3.5	2.3	1.4	1.4	*	0.20	1.1	2.0	1.6	899.2	56.2

Axial and radial force values apply for unsecured housing

* Up to 13.3 lbf-ft one thread aside (at position I) and two frontal threads
From 36.9 lbf-ft only one thread aside and frontal

Dimensions

Torque sensor with standard square socket connection
Version QA

- With rotating shaft
- Drive - inside square socket
- Output - external square drive
- Rotational angle measurement
- Pulse-tool suited, oilproof design (optional)



Table Version QA (with rotational angle measurement)

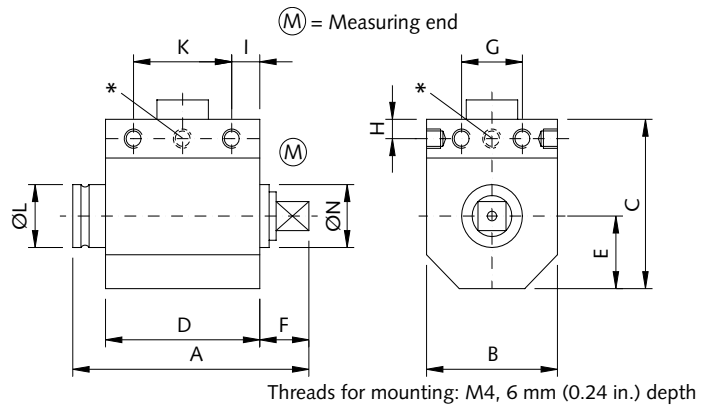

Type	Measuring range lbf-ft	Square size	A	B	C	D	E	F	G	H	I	K	øL	øN	Axial force lbf max.	Radial force lbf max.
4502A12QA	8.9	1/4"	3.0	1.1	2.0	2.3	0.55	0.33	0.32	0.20	0.43	-	0.51	0.39	33.7	6.7
4502A18QA	13.3	1/4"	3.0	1.1	2.0	2.3	0.55	0.33	0.32	0.20	0.43	-	0.51	0.39	33.7	6.7
4502A50QA	36.9	3/8"	4.0	1.5	2.3	2.3	0.75	0.85	0.55	0.20	0.47	1.4	0.99	0.67	112.4	13.5
4502A63QA	46.5	3/8"	4.0	1.5	2.3	2.3	0.75	0.85	0.55	0.20	0.47	1.4	0.99	0.67	112.4	13.5
4502A100QA	73.8	1/2"	4.2	1.5	2.3	2.3	0.75	1.0	0.55	0.20	0.47	1.4	0.99	0.67	157.4	22.5
4502A150QA	110.6	1/2"	4.2	1.5	2.3	2.3	0.75	1.0	0.55	0.20	0.47	1.4	0.99	0.67	224.8	22.5
4502A160QA	118.0	1/2"	4.2	1.5	2.3	2.3	0.75	1.0	0.55	0.20	0.47	1.4	0.99	0.67	224.8	22.5
4502A250QA	184.4	3/4"	5.3	2.3	3.0	2.5	1.1	1.6	1.2	0.20	0.55	1.4	1.6	1.2	449.6	33.7
4502A300QA	221.3	3/4"	5.3	2.3	3.0	2.5	1.1	1.6	1.2	0.20	0.55	1.4	1.6	1.2	449.6	33.7
4502A500QA	368.8	3/4"	5.3	2.3	3.0	2.5	1.1	1.6	1.2	0.20	0.55	1.4	1.6	1.2	449.6	33.7
4502A1KQA	737.6	1"	7.0	2.9	3.5	2.9	1.4	2.3	1.8	0.20	0.55	1.8	2.0	1.6	899.2	56.2

Axial and radial force values apply for unsecured housing

* Up to 13.3 lbf-ft respectively one thread aside (at position I) and respectively two frontal threads (6x M4, 6 mm depth)

Torque sensor with standard 1/4" hex
DIN3126 form E/F, Version H or HA

- With rotating shaft
- Drive - hex shaft
- Output - hex socket
- Rotational angle measurement (Version HA)
- Quick action chuck



Table Version H or HA (with rotational angle measurement)

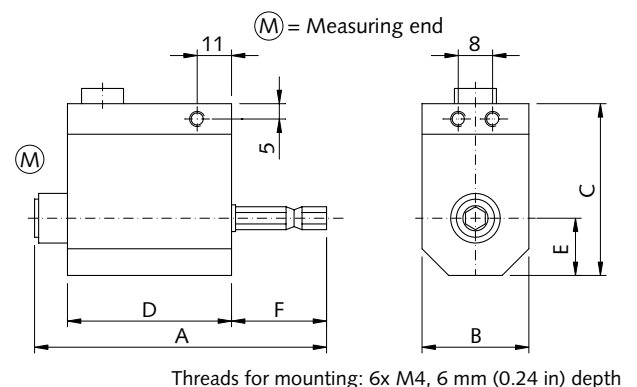

Type	Measuring range lbf-ft	A	B	C	D	E	F	Axial force lbf max.	Radial force lbf max.
4502A0.5H, ...HA	0.37	4.0	1.1	2.1	2.3	0.55	1.1	4.5	1.1
4502A1H, ...HA	0.74	4.0	1.1	2.1	2.3	0.55	1.1	11.2	2.3
4502A2H ...HA	1.5	4.0	1.1	2.1	2.3	0.55	1.1	11.2	4.5
4502A6H, ...HA	4.4	4.0	1.1	2.1	2.3	0.55	1.1	33.7	9.0
4502A12H, ...HA	8.9	4.0	1.1	2.1	2.3	0.55	1.1	33.7	9.0
4502A18H, ...HA	13.3	4.0	1.1	2.1	2.3	0.55	1.1	45.0	9.0

Axial and radial force values apply for unsecured housing

4502A_000-597a-11.07

Dimensions

Torque sensor 0.74 ... 36.9 lbf-ft with shaft end, Version R or RA

- With rotating shaft
- Rotational angle measurement (Version RA)

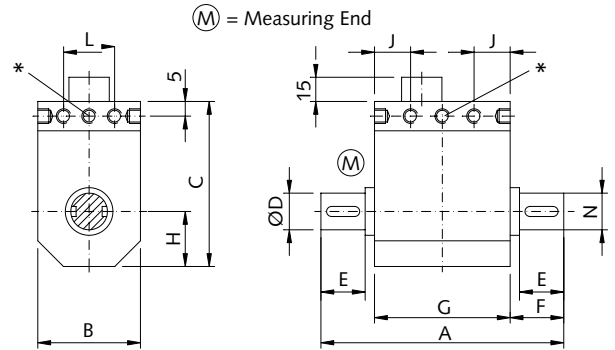
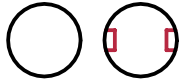

Table Version R or RA (with rotational angle measurement)

Threads for mounting: M4, 6 mm (0.24 in.) depth

Type	Measuring range lbf-ft	A	B	C	øD g6	E	F	G	H	S	J	K	L	N	Axial force lbf max.	Radial force lbf max.
4502A1R, ...RA	0.74	3.6	1.1	2.0	0.39	0.63	0.67	2.3	0.55	0.20	0.43	-	0.32	shaft	4.5	1.1
4502A2R, ...RA	1.5	3.6	1.1	2.0	0.39	0.63	0.67	2.3	0.55	0.20	0.43	-	0.32	shaft	11.2	1.1
4502A5R, ...RA	3.7	3.6	1.1	2.0	0.39	0.63	0.67	2.3	0.55	0.20	0.43	-	0.32	shaft	11.2	2.2
4502A10R, ...RA	7.4	3.6	1.1	2.0	0.39	0.63	0.67	2.3	0.55	0.20	0.43	-	0.32	shaft	33.7	4.5
4502A20R	14.8	4.3	1.5	2.3	0.75	1.2	1.3	1.7	0.75	0.24	0.47	1.4	0.55	s/k**	33.7	6.7
4502A50R	36.9	4.3	1.5	2.3	0.75	1.2	1.3	1.7	0.75	0.24	0.47	1.4	0.55	s/k**	45.0	11.2
4502A20RA	14.8	4.1	1.5	2.3	0.63	0.79	0.91	2.3	0.75	0.20	0.47	1.4	0.55	s/k**	33.7	11.2
4502A50RA	36.9	4.1	1.5	2.3	0.63	0.79	0.91	2.3	0.75	0.20	0.47	1.4	0.55	s/k**	45.0	11.2

Axial and radial force values apply for unsecured housing

* For versions ...20R and ...50R only one thread aside and frontal
**With feather keyways (2x180°) according to DIN6885

Torque sensor 73.8 ... 737.6 lbf-ft with shaft end and separate mounting base, Version RA

- With rotating shaft
- Rotational angle measurement

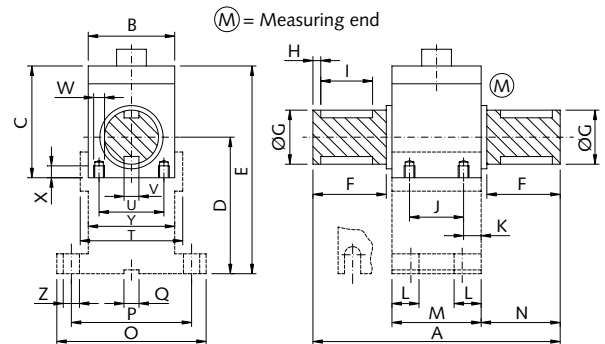

Table Version RA (with rotational angle measurement)

Type	Measuring range lbf-ft	A	B	C	D	E	F	øG g6	H	I	J	K	L	M	N	O	P
4502A100RA	73.8	4.9	2.3	3.0	4.4	6.3	1.1	1.1	0.08	0.87	1.5	0.49	0.79	2.5	1.2	4.7	3.9
4502A200RA	147.5	4.9	2.3	3.0	4.4	6.3	1.1	1.1	0.08	0.87	1.5	0.49	0.79	2.5	1.2	4.7	3.9
4502A500RA	368.8	7.8	2.9	3.5	4.4	6.5	2.3	1.7	0.12	2.0	1.5	0.71	1.0	2.9	2.4	4.7	3.9
4502A1KRA	737.6	7.8	2.9	3.5	4.4	6.5	2.3	1.7	0.12	2.0	1.5	0.71	1.0	2.9	2.4	4.7	3.9

Type	Measuring range lbf-ft	Q P9	T	U	V P9	W	X	Y	Z	Axial force lbf max.	Radial force lbf max.
04502A100RA	73.8	0.39	2.7	1.7	0.32	M5 4x	0.32	-	0.39	89.9	56.2
4502A200RA	147.5	0.39	2.7	1.7	0.32	M5 4x	0.32	-	0.39	89.9	67.4
4502A500RA	368.8	0.39	3.3	2.0	0.55	M6 4x	0.39	2.9	0.39	179.8	89.9
4502A1KRA	737.6	0.39	3.3	2.0	0.55	M6 4x	0.39	2.9	0.39	224.8	89.9

Axial and radial force values apply for unsecured housing

Dimensions

Torque sensor with shaft end and integral mounting base,
Version RAU

- This version can be used as functional check on tilt procedure or rotation monitoring
- Variable mounting positions, applications for left and right hand torque readings as well as the static and dynamic conditions are possible
- All RAU type sensors have an integrated rotational angle measurement

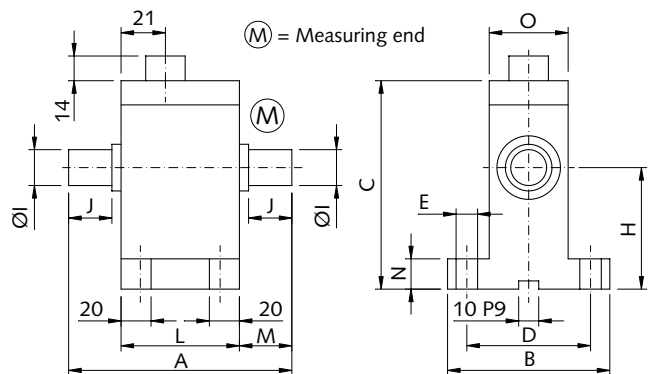
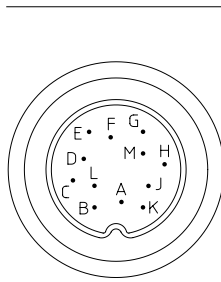

Table Version RAU (with rotational angle measurement)

Type	Measuring range lbf-ft	A	B	C	D	E	H	øI g6	J	L	M	N	O	Size	Axial force lbf max.	Radial force lbf max.
04502A1RAU	0.74	3.5	2.3	3.3	1.8	0.28	1.8	0.39	0.59	2.3	0.63	0.47	1.1	0.04	4.5	3.4
4502A2RAU	1.5	3.5	2.3	3.3	1.8	0.28	1.8	0.39	0.59	2.3	0.63	0.47	1.1	0.04	11.2	5.6
4502A5RAU	3.7	3.5	2.3	3.3	1.8	0.28	1.8	0.39	0.59	2.3	0.63	0.47	1.1	0.04	22.5	11.2
4502A10RAU	7.4	3.5	2.3	3.3	1.8	0.28	1.8	0.39	0.59	2.3	0.63	0.47	1.1	0.04	33.7	11.2
4502A20RAU	14.8	4.2	3.4	4.0	2.4	0.35	2.5	0.67	0.87	2.3	0.91	0.59	1.5	0.08	33.7	33.7
4502A50RAU	36.9	4.2	3.4	4.0	2.4	0.35	2.5	0.67	0.87	2.3	0.91	0.59	1.5	0.08	45.0	33.7

Electrical Connections

Pin Allocation of the 12 Pin Built-in Connector



Function	PIN
Ground, calibration input	A
Angle 1, speed	B
Signal output, U _s ±5 VDC	C
Ground signal output U _s	D
Ground, supply (U _b), angle, speed	E
Supply, U _b +11 ... +26 VDC, 1 W	F
Angle 2 (90° running after angle 1)	G
Supply angle, +5 VDC	H
Not connected	J
100 % control input, Cal., +5 ... 30 VDC	K
Shield	M

4502A_000-597a-11.07

Included Accessories

- None

Optional Accessories

- | | |
|--|----------------------------|
| • Mounting base, for Version RA
ranges 73.8 ... 147.5 lbf-ft | Type/Art. No.
KSM020014 |
| • Mounting base, for Version RA
ranges 368.8 ... 737.6 lbf-ft | KSM020015 |
| • Female connector with solder eye 12-pin | KSM000703 |
| • Connection cable, 5 m, 12-pin – open ends | KSM012497 |
| • Connection cable,
2.5 m, 12-pin – UMV 3000 | KSM018538 |
| • Amplifier for strain gage sensors | 4701A... |

Individual Application

The diverse model range guarantees user-friendly application such as tool calibration or in test stands – with or without mounting base.



Couplings on request

Application Example

Power tool control



Ordering Key

Type 4502A

Measuring Ranges in lbf-ft/

Possible Versions

0.37	-	-	H	HA	-	-	-	-	0.5
0.74	-	-	H	HA	R	RA	RAU	-	1
1.5	-	-	H	HA	R	RA	RAU	-	2
3.7	-	-	-	-	R	RA	RAU	-	5
4.4	-	-	H	HA	-	-	-	-	6
7.4	-	-	-	-	R	RA	RAU	-	10
8.9	Q	QA	H	HA	-	-	-	-	12
13.3	Q	QA	H	HA	-	-	-	-	18
14.8	-	-	-	-	R	RA	RAU	-	20
36.9	Q	QA	-	-	R	RA	RAU	-	50
46.5	Q	QA	-	-	-	-	-	-	63
73.8	Q	QA	-	-	-	RA	-	-	100
110.6	Q	QA	-	-	-	-	-	-	150
118	Q	QA	-	-	-	-	-	-	160
147.5	-	-	-	-	-	RA	-	-	200
184.4	Q	QA	-	-	-	-	-	-	250
221.3	Q	QA	-	-	-	-	-	-	300
368.8	Q	QA	-	-	-	RA	-	-	500
737.6	Q	QA	-	-	-	RA	-	-	1K

Versions

(Note Dependence with Measuring Range)

Square socket	Q
Square socket with rotational angle meas.	QA
1/4" hex socket	H
1/4" hex socket with rotational angle meas.	HA
Rotating shaft	R
Rotating shaft with rotational angle meas.	RA
Rotating shaft with rotational angle meas. and integral mounting base	RAU

Order example:

Type 4502A18HA

Torque sensor: rated torque 13.3 lbf-ft,
Version HA: 1/4" hex socket with angle
measurement